

# **EQUIPMENT AND TEST METHOD FOR MEASURING CUTTING FORCES AND WEAR OF CUTTING EDGES IN SAW TEETH FOR WOOD, IMPROVED WITH NEW HVOF COATINGS.**

**Bonamini G.\*, Collet R.\*\*, Del Taglia A.\*, Fibbi F.\*, Goli G\*, Remorini R\*, Uzielli L.\***

**\* University of Florence - Italy**

**\*\* C.T.B.A. Paris - France**

## **INTRODUCTION**

Woodworking mills constantly ask blade manufacturers and research laboratories to improve the service life of cutting edges.

An ongoing CRAFT Project named "Beltsaw blades quality improvement thanks to a new tungsten carbide coating sprayed by HVOF<sup>1</sup> thermal projection technique"<sup>2</sup>, explores new projection techniques, through which hard metallic coatings are sprayed at high speed on the cutting edges, making them highly resistant to wearing<sup>3</sup>.

Within such project, our group is executing laboratory testing on several innovative saw teeth coatings, and the evaluation of benefits and drawbacks of each one of them vs. traditional coating with stellite.

The plain assessment of the actual service life of freshly sharpened cutting edges (for instance, of a band saw), would require no special equipment: a small set of sawing tests on industrial band saw machines would work well enough in order to obtain reliable data. However, for practical and economical reasons, before whole band saws are manufactured and tested, a series of tests on individual coated teeth needs to be performed, in order to evaluate which of the proposed coatings is best suited to the required use; therefore we decided to perform the tests on circular blades, carrying just two teeth each, monitoring the progressive wear of the teeth during the cutting process, under carefully controlled working conditions.

This paper describes the testing and measurement apparatus which has been designed and built, in order to perform the testing of the proposed new coatings.

## **THE MEASURING AND TESTING APPARATUS**

The apparatus is composed by four main parts (see also Table 1 and the block diagram in Figure 1):

- a test bench (TB)
- a data acquisition and processing system (DAPS)
- a marking and measuring bench (MMB)
- an image analysis system (IAS)

---

<sup>1</sup> High Velocity Oxygen Fuel

<sup>2</sup> Contract n° BRST-CT98-5212, Project n° BE-5281

<sup>3</sup> The project is co-ordinated by CEA/CERAM (Fr) and the partners are: MFLS (FR), HOLTWERKE ZIEGLER (DE), DUCERF SA (FR), SEYNA (BE), HH BOOGAERDT BV (NL), FIRST (IT), FIP (IT), BAUWENS GASTON (BE), CTBA (FR), IATF (IT).

**Table 1 - Components of the testing and measuring apparatus**

Test Bench - TB	A purpose-built circular sawing machine, featuring special disk blades equipped with two test-teeth; given lengths of wooden boards are sawn under controlled infeed and cutting speed, in order to obtain constant chip thickness. Harmful vibrations are prevented by the machine design.
Data Acquisition and Processing System - DAPS	The above mentioned test bench is equipped with analogic <u>speed</u> , <u>force</u> and <u>apparent power consumption</u> transducers, connected to a PC unit through a 12-bit A/D interface. Software routines perform any required signal acquisition and processing; data may then be examined through display (PC monitor), printer or export-files. The information acquired can be used to give an indirect estimate of the increasing wear of the test tooth in relation to the length of wood cut by its edge.
Marking and Measuring Bench - MMB	In order to perform a direct measurement of wear, as specified in the following item, some reference marks have to be punched on the test-tooth faces. This equipment makes precise, easy and safe the marking procedure by means of a Vickers puncher. The same bench is also used for a close examination of the edge conditions, performed through a microscopic video camera before and after processing given lengths of wood.
Image Analysis System - IAS	Images taken by the camera are digitally acquired and saved on a PC. Each image include both the cutting edge (upper view and side view) and the reference marks. By means of CAD tools, the evolution in the geometry of the cutting edge (blunting) can be reconstructed trigonometrically.

A direct measurement of the wear of the cutting edge, even though requiring a time consuming procedure (dismounting, measuring and remounting the blade), nevertheless provides the analysis with objective and absolute wear data, such as edge *recession* and *dulling* (see the following paragraphs) required both for reference, and possibly for establishing quicker test procedures (e.g. in order to establish limit-values for the related monitoring parameters acquired by the DAPS *during* the test: by exceeding one of them the tooth would be considered as “blunt”).

**Figure 1 - Schematics of the various steps involved in the testing**

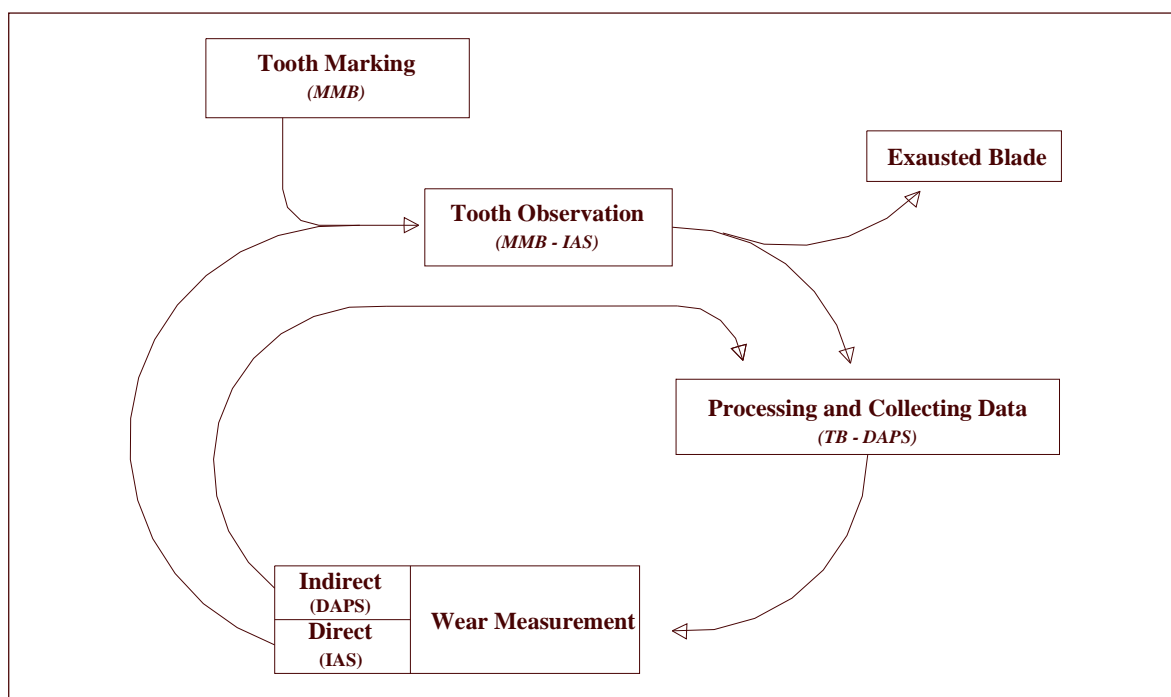

## THE TEST BENCH

The test bench (Figure 2) has been designed and built on purpose for this research; its main features are listed in Table 2.

**Table 2 - Main features of the test bench**

Concrete base, approx. 2000 kg heavy, supported by rubber vibration-damping blocks.
Structure, built up with H section bars strengthened by welded steel plates
Work top, made of 110 mm thick LVL
Electric motor (3 kW, variable speed controlled by a 3-phase inverter)
Triaxial dynamometric piezoelectric platform, to measure cutting forces during the sawing process
Variable speed feeder, with rubber rollers
Safety coverings and protections
Dust suction equipment
Control panel (infeed speed; motor speed; data acquisition system)

**Figure 2 - The test bench**

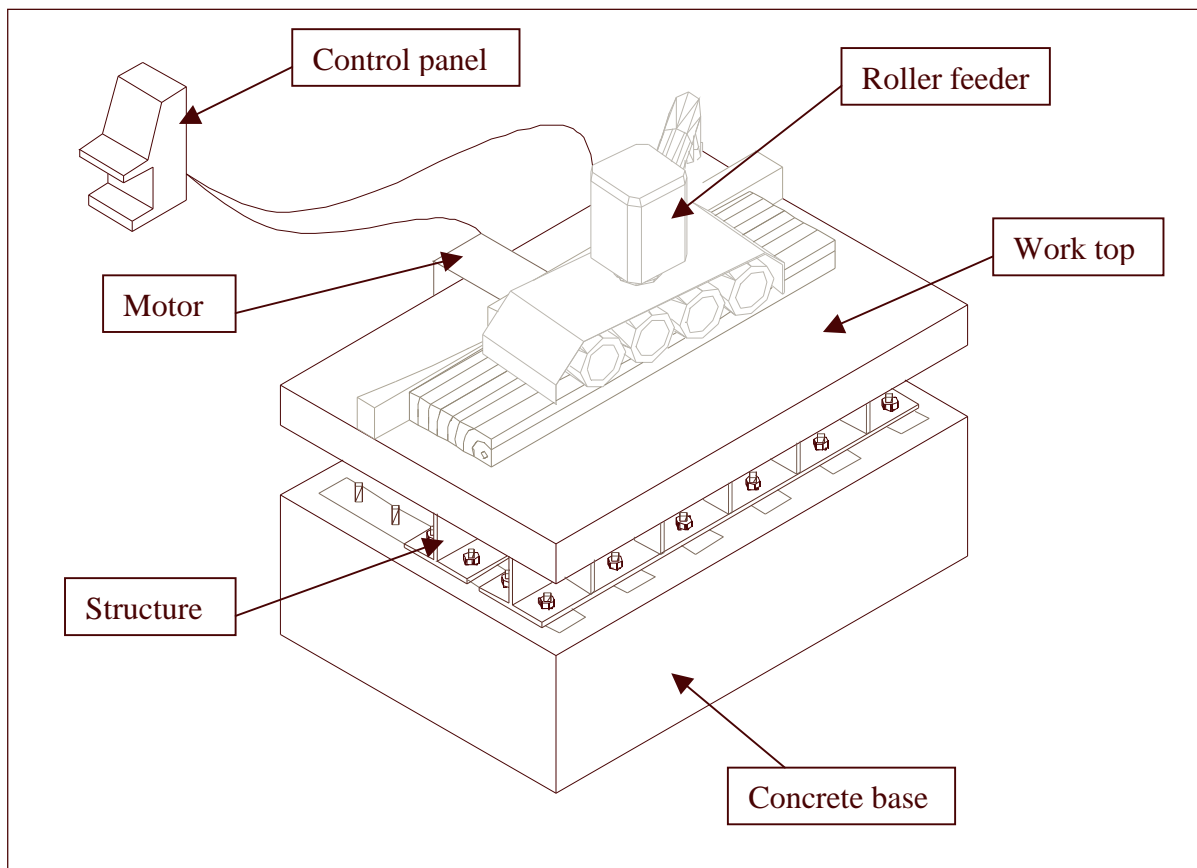

Positive features of this sawing machine are:

- damping off harmful vibrations
- possibility of changing the position of the work top
- work top made of LVL, a material easy to process and modify if needed
- speed of motor and roller feeder accurately controlled .

The reasons of choosing two-teeth circular steel blades are mainly the following:

- a disk requires no adjusting of variables such as blade tension (which, on the contrary, is needed for gang saw and band saw blades)
- a two-teeth blade is balanced, and at the same time requires cutting a minimum length of wood in order to obtain a measurable wear; furthermore, only one tooth at a time is engaged in the cutting process, minimising disturbances in the measurement of cutting forces
- the measured data are obtained from a real sawing process; furthermore, they can be acquired during the whole cutting operation.

## DATA ACQUISITION AND PROCESSING SYSTEM

The forces exerted by the wood on the tooth are measured by the triaxial dynamometric platform<sup>4</sup> on which the motor is placed; in fact, the reaction to the cutting force is measured, through the motor. In order to minimise the inertia forces acting on it, the motor has been kept as light as possible, however some problems do arise from vibrations, as mentioned further in this paper. The measuring system and the direction of reference axes are shown in Figure 3.

**Figure 3 - Measuring system and directions of axes**

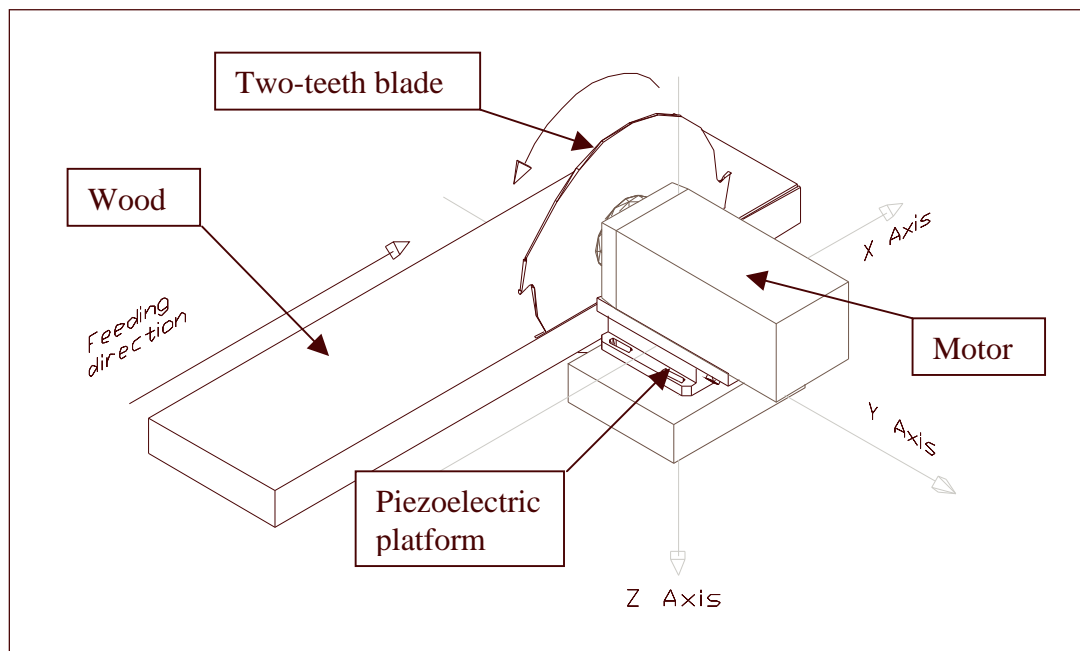

The apparent power absorption is measured continuously by the electronic system that supplies power to the motor and controls its speed, which is monitored by a laser pulse counter.

All the signals are fed into a computer aided acquisition system which converts the data into the digital domain and records them on hard disk.

---

<sup>4</sup> The dynamometric transducer is formed by two superposed steel rectangles; four three-axial piezoelectric transducers are placed between the two parts, near the four corners. The piezoelectric system averages the signals of the four transducers along each axis; the force exerted on the platform is therefore decomposed along three Cartesian perpendicular axes, and is not influenced by the applied moments.

The system is equipped with a managing software created by a graphical programming for instrumentation software package (LabVIEW™), which controls an acquisition board (sampling rate 30 kHz) mounted on the computer<sup>5</sup>.

## THE MARKING AND WEAR EVALUATION BENCH

For the measurement of wear we designed and built a bench, to adjust and hold firmly the circular saw-blade in the correct positions for the two following operations:

- punching permanent marks on selected faces of each tooth; such marks being the reference system against which recession and shape of the cutting edge may be measured
- taking the images of the teeth, in order to analyse the wear of the cutting edge after having sawn given lengths of wood.

### The marking system

Marking is performed with the indenter of a Vickers hardness tester; i.e. with the point of a pyramid-shaped diamond; thanks to such shape (square base, summit angle  $136^\circ$ ) a mark with a well visible centre can be obtained. The blade is mounted twice on the bench: once vertically, so that the clearance face of the tooth may be marked, and once almost horizontally, so that a lateral face may be marked. For the lateral marking, the blade support is mounted over a system of hinges so it may be rotated along two axes, until the lateral face of the tooth (rather than the blade plane) is perfectly horizontal.

The rotation of an eccentric holder of the indenter makes it possible to displace the marking diamond by given amounts, so that marks are precisely placed at the desired distance and angle from each other; the pattern of marks locates two orthogonal reference axes (see Figure 4 & 5).

**Figure 4 - The marking and measuring bench**

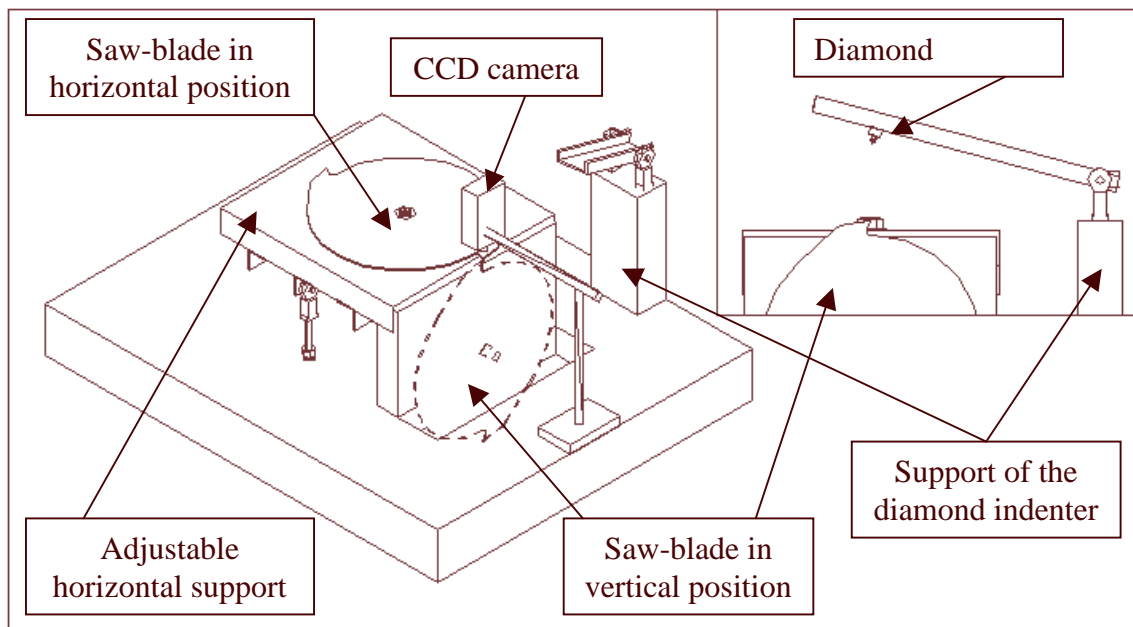

<sup>5</sup> The data are saved on hard disk under .bin format to economise space. The data can be read with all the acquisition sets and operator comments, to be displayed, printed, processed and so on. Furthermore the data can be saved under spreadsheet application format to be read and processed with other software packages.

## The image acquisition and analysis system

The same bench is also used for the close examination of the edge conditions, performed before and after processing given lengths of wood, by means of a video camera equipped with a microscope lens. The camera is mounted on a micrometrically adjustable arm, and needs no large displacements when the blade is moved from vertical to horizontal position, since the observed part of the tooth can be adjusted in the same location, thanks to the bench design.

Images are acquired through the CCD camera (570 lines resolution), are processed by means of an image analyser (Quantimet 500), and finally are digitally stored; geometric measurements are then performed on the recorded images by means of a CAD software.

The measurements of the shape of the cutting edge and of its distance from the reference marks define its *dulling* (on the lateral face) and its *recession* (on the clearance face), as shown in Figure 5. Initial measurements are made on the newly sharpened tooth; further measurements are performed on that same tooth at fixed intervals, after it has cut given lengths<sup>6</sup> of wood chips.

**Figure 5 - The reference marks on the tooth faces, for measuring *dulling* and *recession* of the cutting edge**

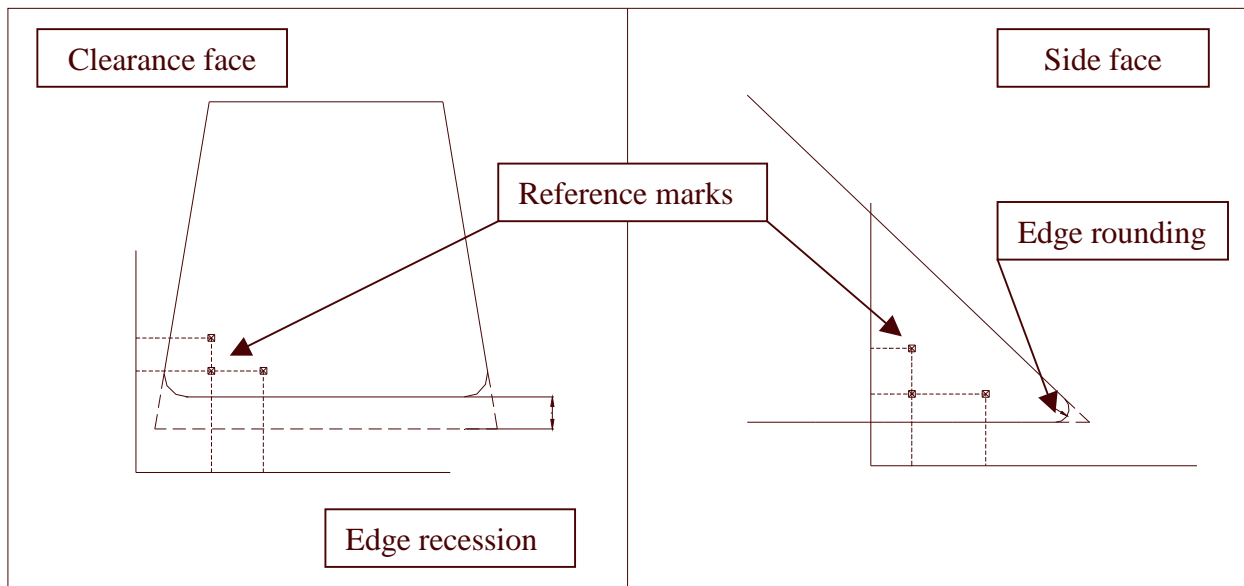

## EXPERIMENTAL DESIGN OF TESTS

Cutting tests should approach as much as possible the sawing conditions of a band saw, even though they are performed with a circular saw for the sake of economy and practical feasibility.

Each disk blade carries two opposed teeth (see Figure 6), for balancement reasons; the same coating is on both teeth, because a different wear resulting from two different coatings could lead to different chip thicknesses, and therefore to irregularities in the cutting process, including wearing conditions and cutting forces.

Disks are 400 mm in diameter and 3,5 mm thick, which ensure sufficient stiffness and "flywheel effect" (compensating for the irregularity caused by the low number of teeth) during the cutting process.

<sup>6</sup> E.g. measurements have been performed every 1000 metres of chip length, for stellite-tipped teeth cutting Azobé (*Lophira alata* Banks - a very dense and abrasive wood also named Ekki).

Rotation speed of the motor can range between approx. 0 and 3000 rpm; the value of 1800 rpm has been chosen, in order to obtain a cutting speed of 38 m/s with a 400 mm disk.

Infeed speed of the board, determined by the roller's speed and diameter, can range between 2 and 33 m/min (other speeds can be obtained by changing gears or rollers); the value of 2 m/min has been chosen, in order to obtain a maximum chip thickness of 0,56 mm.

The testing has been conceived so that the least possible amount of wood is wasted; therefore a strip as thin as 3 mm is sawn at every passage, in order to ensure a) sufficient safety distance between the blade and the still guide, and b) sufficient thickness of wood on both sides of the blade, so to reproduce a normal sawing process. Since the saw kerf is 4,5 mm, each sawing passage takes away approximately 7,5 mm from the board width.

The thickness of boards is typically 60 mm, resulting in a chip length of 70 mm which has been estimated sufficient, in order that the heating of the cutting edge may reproduce, at the cutting edge, the conditions of a band-saw cutting a log.

The length of chip being 70 mm, and its thickness along the feeding direction approximately 0,56 mm, a total length of 1000 metres of cut chip is obtained with 14285 tooth passages, i.e. by sawing from the boards several strips, totalling 8 meters length, or 3,6 dm<sup>3</sup> of solid wood.

The feeder rollers push the wood towards the blade direction over a bed of steel slides, to minimise friction.

**Figure 6 - The two-teeth blade type used in the tests**

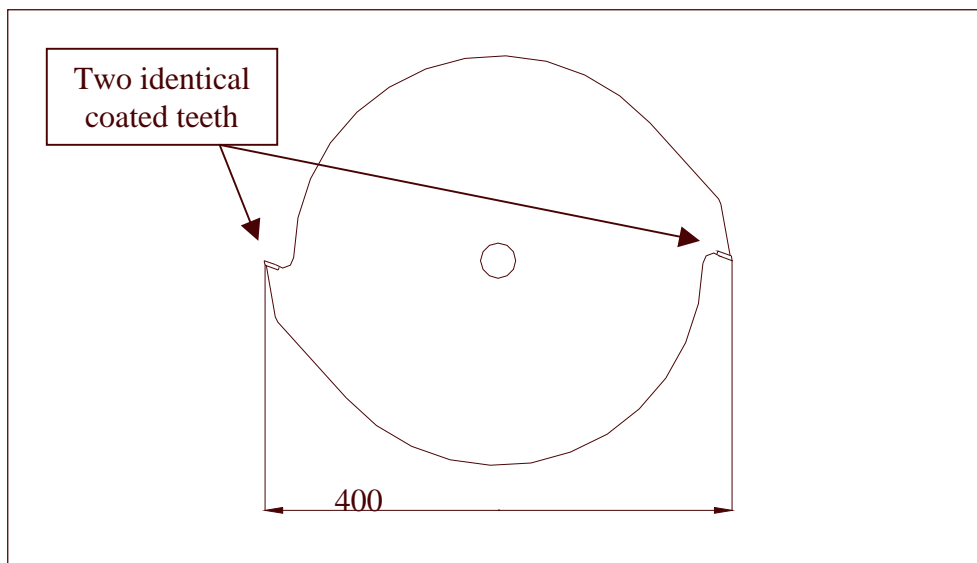

## RESULTS

The wear tests have not yet been completed; however, all data concerning coatings and results need to be kept confidential, since they belong to the industries participating into the CRAFT research project.

### The test bench

Thanks to the accurate design, all details of which were defined before starting the actual construction work, since its initial tests the test bench has been found efficient, versatile, safe and easy to modify or adapt to specific needs. The boards (even if made of Azobè, already cited as a

quite difficult wood) are easily engaged by the feeder and sawn, without significant vibrations or other problems.

### The data acquisition system

The recorded values of motor speed and of power absorbed during the sawing process are quite accurate and reliable.

The forces developing between teeth and wood are measured by the piezoelectric triaxial platform: although the high quality of transducers, amplifiers and cables provides high quality and low-ripple signals, some problems arise from the vibration of the platform-motor assembly, which behaves like a mass-spring system<sup>7</sup>. Such vibration generates an alternating force which is picked up by the platform, and adds to the force generated by the contact between tooth and wood; since the vibration has low decay rate, its damping time is longer than the interval between two successive impacts of teeth on wood, and the measurement of the true cutting forces is partially masked by such effects.

The amplitude of the measured impulse (i.e. the first force peak after each impact) will therefore result not exclusively from the force exerted on the saw by the tooth, but from the amplitude and timing of the disturbing vibrations as well.

Figure 7 shows a sawing test on a 60 mm thick Azobè board. The impact points (especially on the Z axis) can be easily identified because of a) the abrupt change of the wave-form and b) of the larger amplitude of the wave' peak. Damping starts immediately after the impact, but the system's vibration is still large when the following impact occurs.

**Figure 7 - Sawing test obtained processing a 60 mm thick Azobè board with a stellite coated blade**

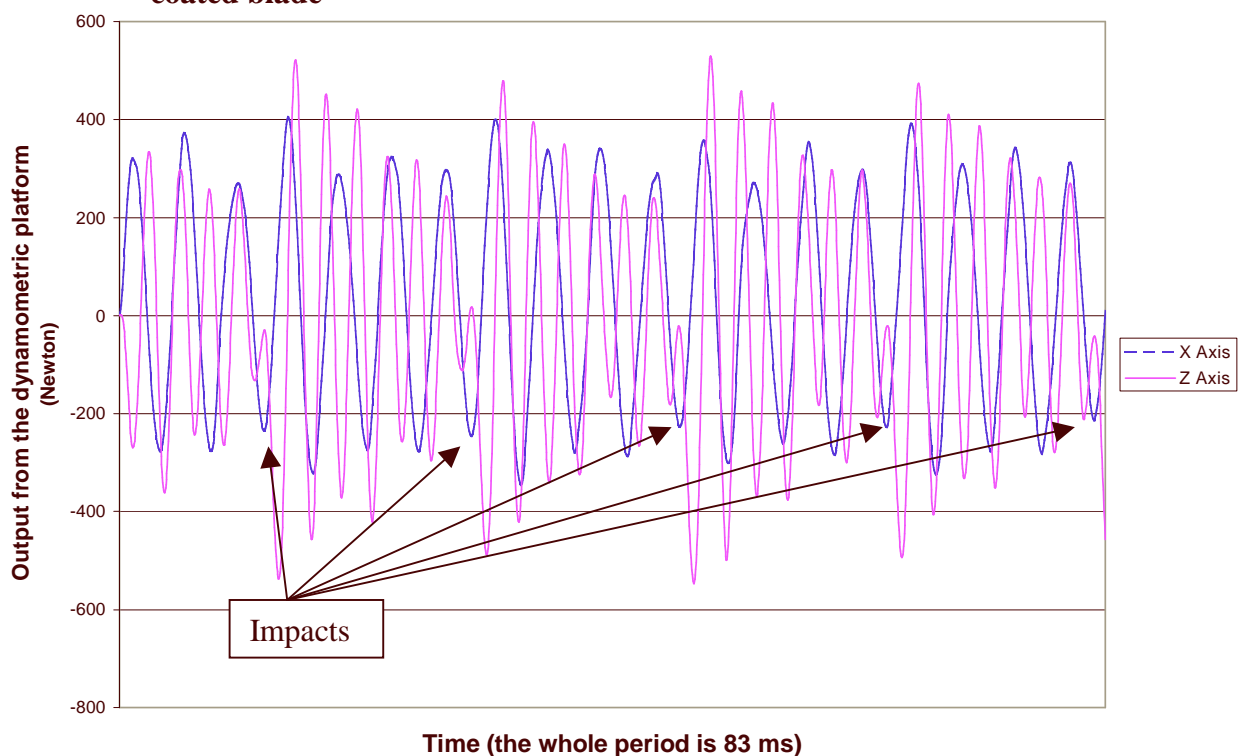

<sup>7</sup> The mass consists of the motor with its supports, the saw disk, and all the components placed on the platform (including the platform's upper part); the springs are the piezoelectric elements. The natural frequencies of this system have been determined by recording its free vibration after striking the motor with a wooden hammer; frequency is 400 Hz along the Z axis (vertical) and 250 Hz along the X axis (horizontal).

Such disturbance interferes with the analysis of the cutting forces, since the presently recorded values are insufficiently "clean" for successive processing<sup>8</sup>. Further research is ongoing in order to overcome this problem.

## CONCLUSION

From the mechanical and processing point of view, the test bench described here is easy and safe to use, and fulfils the requirements of the wearing tests. The blades can be quickly taken away and re-mounted, significant lengths of wood can be processed rapidly and continuously, and the sawing parameters can be easily adjusted to desired values, and monitored.

However, the bench also allows for collection of further data (power consumption and cutting forces) during a real sawing process. Data are recorded on a computer system and can be read again (by a specific software) to be processed and compared; furthermore, they can be used to monitor indirectly the wearing process in real time, and correlations may be established between wear and the above mentioned processing parameters (power consumption and cutting forces).

Measurement of cutting forces is also possible, but is presently disturbed by vibrations which interfere with their analysis; further research is ongoing in order to overcome this problem.

## REFERENCES

Simmond A.; *Wide bandsaws*; Stobart & Son Ltd.; London 1980.

CEA/CERAM; *"Belt Saw Blades quality improvement thanks to a new tungsten carbide coating sprayed by HVOF thermal projection technique"*; Project Programme, Grenoble 1997.

Loehnertz Stephen P., Vazquez Cooz Iris; *Sawtooth Forces in Cutting Tropical Hardwoods Native to South America*; United States Department of Agriculture, Forest products Laboratory, Research paper FPL-RP-567.

National Instruments; *G Programming Reference Manual*; January 1998.

National Instruments; *LabVIEW Data Acquisition Basics Manual*; January 1998.

---

<sup>8</sup> Presently the X and Z components of the cutting forces are measured and recorded, such axes being fixed with the test bench and the motor; in order to well analyse the cutting process, force components should be re-composed along a system of rotating axes integral with the saw disk. Such processing requires exact knowledge of instant values, synchronised with the disk angular position, and cannot be performed until true force values are available, free from vibration disturbance.