

DUPLEX TREATMENT BASED ON THE COMBINATION OF ION NITRIDING AND PVD PROCESS : APPLICATION IN WOOD MACHINING

Chala Abdelouahad¹, Chekour Lounis², Nouveau Corinne³, Djouadi Abdou⁴, Goli Giacomo⁵

¹ Physics Dept., University of Biskra
B.P. 145 RP, 07000 Biskra, Algeria
chala@cluny.ensam.fr

² Physics Institute, University of Constantine
Route de Ain El Bey, 25000 Constantine, Algeria
chekour.lounis@caramail.com

³ Ecole Nationale Supérieure d'Arts et Métiers (ENSAM)
Rue Porte de Paris, F-71250, Cluny, France
nouveau@cluny.ensam.fr

⁴ Institut des Matériaux Jean Rouxel, UMR 6502
2 rue de la Houssinière, B.P. 32229, F-44322, Nantes cedex 3, France
Abdou.Djouadi@cnrs-immn.fr

⁵ Ordinario di Tecnologia del Legno, Università di Firenze
13 via San Bonaventura, 50145 Firenze, Italia
giacomo.goli@cluny.ensam.fr

ABSTRACT

The aim of the study is to optimise the application of duplex treatments by modifying the nitriding conditions in high temperature process. The influence of gas mixture (composed of N₂, H₂ and CH₄) and time of nitriding on the mechanical and structural properties of 32CrMoV13 low alloy steel samples was studied. The composition and structure of the nitrided layers was determined by EDS and XRD respectively. Vickers micro hardness profiles were also performed to study the influence of the gas mixture and time of nitriding. The morphology of the nitrided layers was observed by optical microscopy. Cubic Cr_xN_y coatings have been realised by triode sputtering on both faces of the steel cutting knives. EDS analyses permitted to verify the composition of the layers while their structure was determined by XRD. Different kind of cutting knives were tested in peeling of non-defect beech wood: untreated, nitrided, CrN-triode sputtered and CrN-duplex treated cutting knives. The friction coefficient between the cutting material and the wood was determined and the wear of the knife edge (reduction of the edge) was also measured.

The time of nitriding was influent on the diffusion layer's thickness and properties. Furthermore, it was obvious that increasing the nitrogen contents from 20 to 80% in the nitriding gas mixture N₂+H₂ or adding 5% of methane permits to increase the nitrided layer's

thickness and hardness. The nitrided cutting knives and CrN-triode sputtered duplex based treated knives were tested and compared in peeling of beech. The duplex treated knives obtained with 80% of N₂ or 5%CH₄ performed best and allowed to increase almost twice the tools service life.

INTRODUCTION

Actually, hard coatings are commonly used to increase the wear resistance of cutting tools in metal machining¹. In wood machining, even if the application of coatings as wear or corrosion protection of cutting knives is not common, some previous works² showed their efficiency in peeling and routing. Even if the coatings allowed increasing the service life of the cutting tools, their adhesion is not sufficient. This could be a limit to their employment and marketing. Nevertheless, the solution to increase the adhesion of the coatings on steel tools was to realise a previous nitriding to the tool before the coating: that means to make a duplex treatment. Previous works showed the efficiency of TiN-based^{3,4}, Cr₂N-based⁵ and TiN/TiAlN-based⁶ duplex treatments. Smolik et al.⁷ particularly showed that CrN-based duplex treatments performed the best compared to TiN-based ones in wear tests with a Z155CrMoV131 steel ball. A preliminary study was realised on steel 60SMD8, unsuitable for nitriding, but commonly used in peeling of beech². During the peeling of beech, the CrN-based duplex treatments permitted to increase 4 times the service life of cutting knives while the CrN-coated ones permitted to increase the service life only 1,3 times. The aim of this work is to complete the study of the application of CrN-based duplex treatments by determining the influence of nitriding parameters, such as the gas mixture, and especially methane, and the time of treatment on the mechanical and structural properties of nitrided steel samples and knives. The steel material was 32CrMoV13 low alloy steel, of composition: C 0.3, Si 0.31, Mn 0.5, Cr 3.25, Mo 0.44, Ni 0.11, V 0.1, commonly used for nitriding and presenting a good tenacity.

EXPERIMENTAL

Nitriding process

Nitriding treatments have been carried inside a low vacuum furnace (450x450x450 mm³) equipped with an impulsive current generator. The temperature of the samples is followed thanks to a thermocouple very close to them. The type of nitriding layers and their qualities depend on the type of gas mixture, the pressure and time of nitriding process^{3,8}. The applied nitriding conditions are summarized in Table 1. The cutting material 32CrMoV13 was chosen because it presents a good amount of Cr, Mo and V necessary for a good nitriding. The treated cutting tools were tested in peeling of beech.

	Gas mixture	Time of nitriding (hours)
A	20% N ₂ + 80% H ₂	2, 4, 6, 8
B	20% N ₂ + 75% H ₂ + 5% CH ₄	2, 4, 6, 8
C	75% N ₂ + 20% H ₂ + 5% CH ₄	2, 4, 6, 8
D	80% N ₂ + 20% H ₂	8

Table 1. Nitriding conditions applied on 32CrMoV13 steel at 510°C.

The thickness and morphology of nitrated layers were observed by optical microscopy on cross sections (OLYMPUS VANOX-T AH-2 microscope). The composition of the nitrating layers was verified by EDS (Energy Dispersive Spectroscopy) analyses and X-Ray Diffraction analyses (SIEMENS D500 - K_{α} (Co) radiations) were performed to determine their structure.

XRD analyses were also used to determine the residual stresses of these layers (Diffractometer Siemens D500 - K_{α} (Cr) radiations)⁹. The stress profiles were obtained after erosion of 10 to 60 μm in anodic dissolution with an appropriate electrolyte. The used peak was the Fe (211) and the radiocrystallographic constant $\frac{1}{2} S_2(211)$ was taken to the one of Fe : $0,585 \cdot 10^{-5} \text{MPa}^{-1}$. Vickers hardness measurements (microdurometer LECO AMH 100 - load 200 g) have been also performed on steel samples.

Deposition procedure

The chromium nitride films were deposited by reactive triode sputtering. The deposition parameters were determined in previous works¹⁰. Steel tools, friction slippers and samples were ultrasonically cleaned in ethanol. Before deposition, the target disc and the samples were cleaned by sputtering for 5 minutes in an Ar discharge. The tools were CrN-coated on both sides with a deposition rate of 2,4 $\mu\text{m}/\text{h}$ and the coating thickness is fixed to 1 μm .

Peeling process

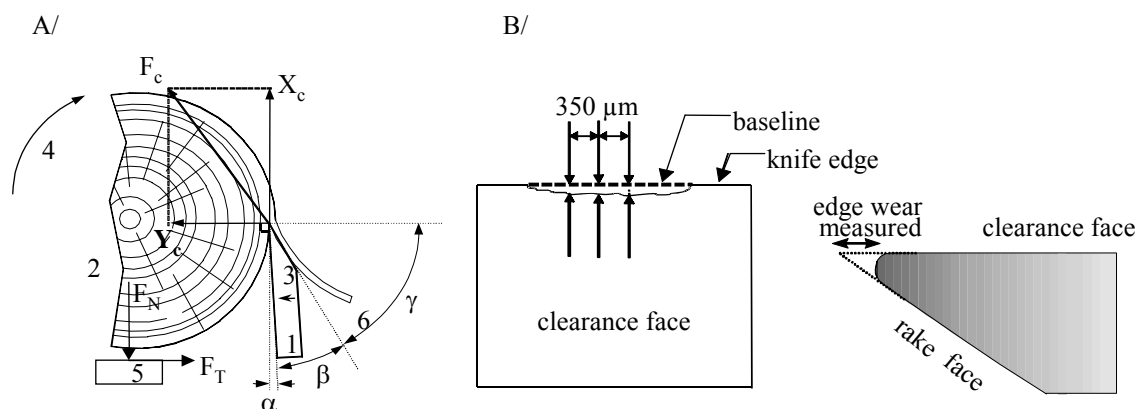

Fig. 1. (A) Peeling process (1-cutting knife, 2-wood disk, 3-knife movement, 4-rotation direction, 5-friction slipper, F_N -normal force, F_c -resultant force of the knife) – (B) Measurement of the cutting edge reduction

The experiment was performed using a home-made peeling laboratory apparatus which enables the friction coefficient measurements thanks to piezoelectric sensors¹. The system is described in figure 1A. Before the nitrating process, all of the tools and samples were heat-treated (quenching 920 $^{\circ}\text{C}$ + tempering 550 $^{\circ}\text{C}$) to reach a hardness of around 500 HV.

The material subjected to the cutting experiments was defect-free beech wood (*Fagus sylvatica* L, 0,6-0,7 g/cm^3). The cutting parameters were constant in all the peeling operations: linear cutting speed 0,5 m/s, clearance angle 3 $^{\circ}$, veneer thickness 0,3 mm, wood disk width 15 mm, cutting path 5000 m (beech wood). The reduction of the cutting edge represents the tool wear and its measurement is represented on figure 1B.

RESULTS AND DISCUSSION

Nitriding optimisation

The presence of nitrogen was verified by EDS analyses which reveal a peak at 392 eV characteristic of N ($K_{\alpha 1}$). For all gas mixtures, we found that this peak increases with time (Fig. 2A, B, C,D).

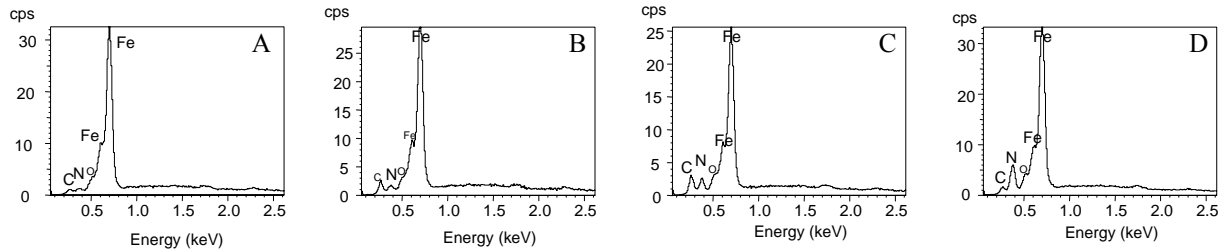

Fig.2. EDS spectra corresponding to 75%N₂+20%H₂+5%CH₄ gas mixture ((A) 2, (B) 4, (C) 6 and (D) 8 hours).

Optical observations of the nitrided layers reveal the presence of a thin white layer (2-20 μ m) and a diffusion layer obtained in B, C and D gas mixture for all times. However, we don't found a white layer in A gas mixture whatever the nitriding time (Fig.3A). This layer was observed in the other gas mixture after only 2 hours of nitriding time (Fig.3B,C,D).

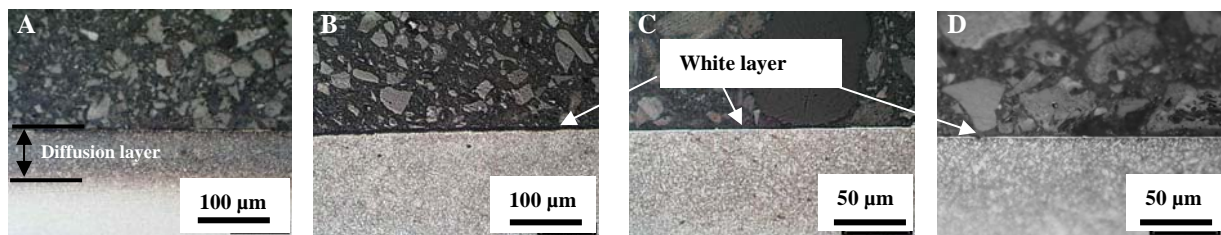

Fig. 3. Cross-section observations of steel samples nitrided in: (A) 8 hours in gas mixture A, (B) 2 hours in gas mixture B, (C) 2 hours in gas mixture C, (D) 2 hours in gas mixture D.

The presence of a dense white layer was verified by XRD analyses (Fig. 4). Composed of two phases γ' (Fe₄N) et ϵ (Fe₂₋₃N), this layer is present in B, C and D samples. It appears that the thickness of the γ' phase decreases when the nitrogen contents of the nitriding gas mixture increases or when methane is present. Confente et al.¹² showed that in both cases, it tends to generate or stabilise the ϵ phase in the nitrided layer. In this case, we observe an increase of the well crystallised ϵ diffusion layer's thickness on the XRD patterns.

It also appears that the thickness of the diffusion layer is thinner in the case of the mixture A, where the Fe (200) and (211) peaks are still well detected in comparison to the other mixtures, where only broad Fe (211) and (110) peaks are observed. Furthermore, for 20% of nitrogen in the nitriding gas mixture, only the ϵ (002), ϵ (110) and ϵ (112) peaks are detected. When the nitrogen contents increases to 80%, ϵ (100), ϵ (211), ϵ (101), ϵ (121), ϵ (102) and ϵ (103) peaks are also detected. The influence of methane decreases due to the saturation of nitrogen concentration.

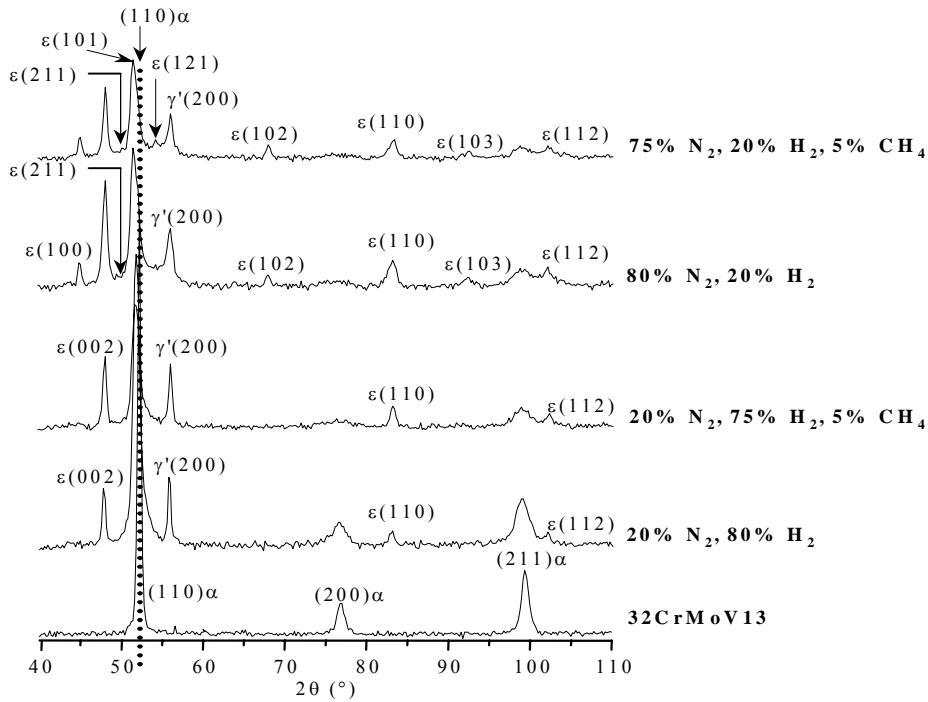

Fig. 4. XRD patterns as a function of the nitriding gas mixture after 8 hours of nitriding.

The hardness profiles of untreated and nitrided steel samples are represented in figure 5. the steel sample nitrided in a gas mixture A has a higher surface hardness (850 HV) than the untreated one (500 HV) but lower than the three other nitrided steel samples B, C and D which present a surface hardness of around 900 – 1000 HV.

The increase of nitrogen contents from 20 to 80% or the introduction of methane in the gas mixture permit to reach a higher surface hardness. The hardness profiles permit also to verify the nitrided layer's thickness as a function of nitriding gas mixture (Fig.5A) and time of nitriding (Fig.5B). The gas mixture A allowed to get a nitrided layer of 100 μm while other gas mixture with higher N_2 contents or 5% CH_4 allowed to reach a thickness around 200 μm . These results confirm the ones obtained by optical observations (Fig. 3). Furthermore, as expected, the thickness of the nitrided layers increases with the time of nitriding (Fig.5B).

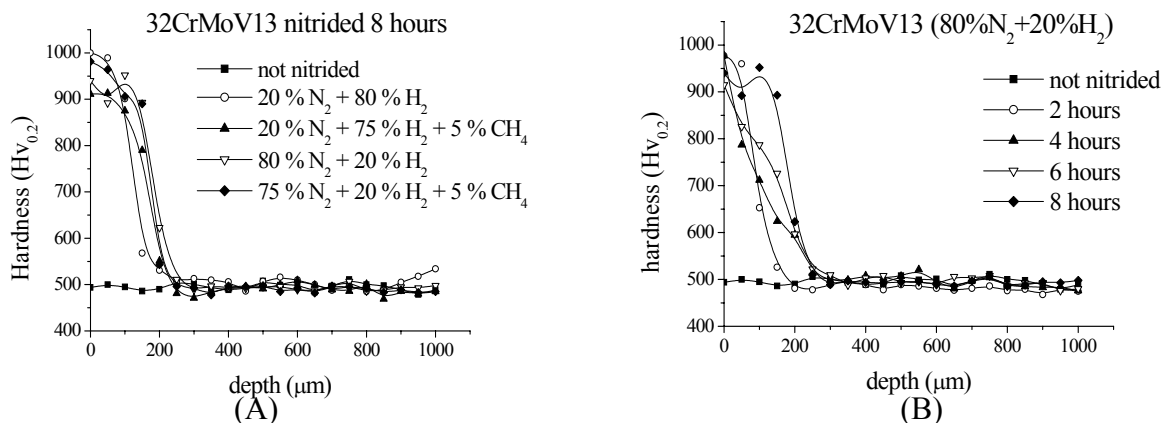

Fig. 5. Vickers hardness profiles as a function of gas mixture (A) and nitriding time (B).

X-Ray measurements present that the nitrided layers have compressive stresses¹³ with a maximum of -800 MPa at the depth of 80 μm (middle of the nitrided layer thickness) (Fig.6). The stress must be homogenous in the nitrided layer because it doesn't depend on the Φ

direction (direction of analyses).

Correlation between the stress and the hardness is shown on the figure 6B but due to surface effect, it was not possible to measure the hardness under 25 μm of depth. We can observe two zones: zone I where the creation of interstitial nitrogen (iron nitrides) and the nitrides precipitation into the matrix is main close to the surface. This is responsible for the increase of hardness and stress simultaneously. In zone II, the stress tends to stabilize or slowly decrease because of a possible relaxation¹³. Previous works showed such correlation for 32CrMoV13 steel samples gas nitrided at 550°C¹³.

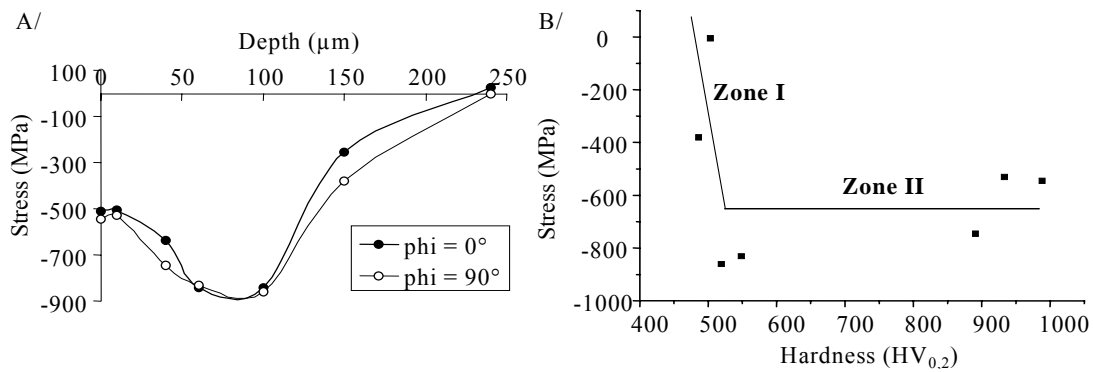

Fig. 6. Stress profiles versus depth (A) - Relation between stress and hardness for a steel sample nitrided with 80%N₂+20%H₂ (B)

Application of duplex treatments in peeling of beech

After the characterisations of the nitrided layers, CrN-tri-oxide sputtered coatings were realised on nitrided cutting knives in view to their application in peeling of beech. The time of nitriding was fixed to 8 hours and the influence of the gas mixture was studied. EDS analyses reveal that the CrN layers have a ratio N/Cr of 1,1. Less than 2 atomic percent of oxygen were detected. The XRD pattern of a duplex treatment (Fig.7) reveals the CrN (111) and CrN (200) orientations and that the layers are well crystallised. Minor signal from CrN (202) and CrN (311) are also detected.

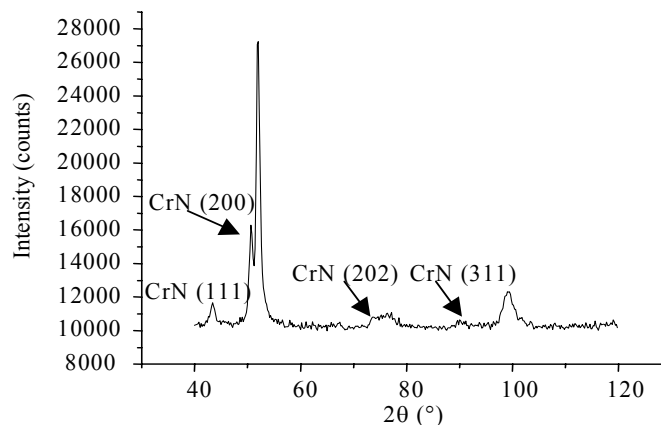

Fig. 7. XRD pattern of a duplex treatment (20%N₂+80%H₂/CrN).

Wood machining tests were performed on an untreated, a CrN-coated, nitrided and CrN-based duplex treated cutting knives (Fig.8). As we can see on figure 8A, after 5000 m of peeling, the reduction of the edge equals to 250 μm for the untreated knife and 200 μm for the CrN-coated one. The CrN layer permits to increase the service of the tool by a factor of 1,3.

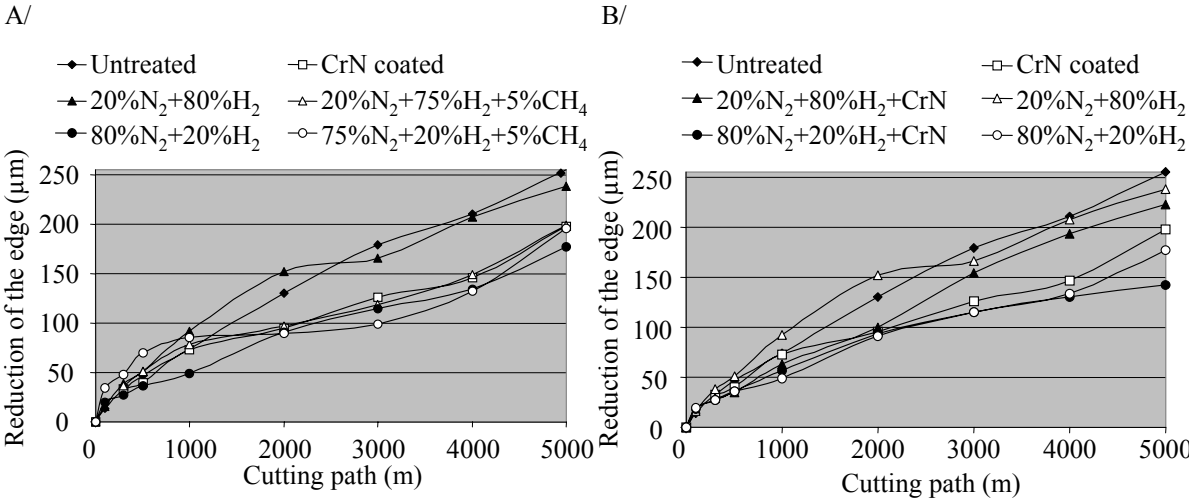

Fig. 8. Reduction for untreated, CrN-coated and nitrided cutting knives (A) and untreated, CrN-coated, nitrided and CrN-based duplex treated cutting knives (B).

This can be explained by a lower friction coefficient of the coated knife (0,374) in comparison to the one of the untreated knife (0,445) (Fig.9). Besides, the knife nitrided in a gas mixture of 20%N₂+80%H₂ has the same behaviour than the untreated one and a similar friction coefficient (0,407). The low surface hardness and the bad adhesion of the nitrided layer observed in a previous study¹⁴ can be responsible for the bad performance of this knife.

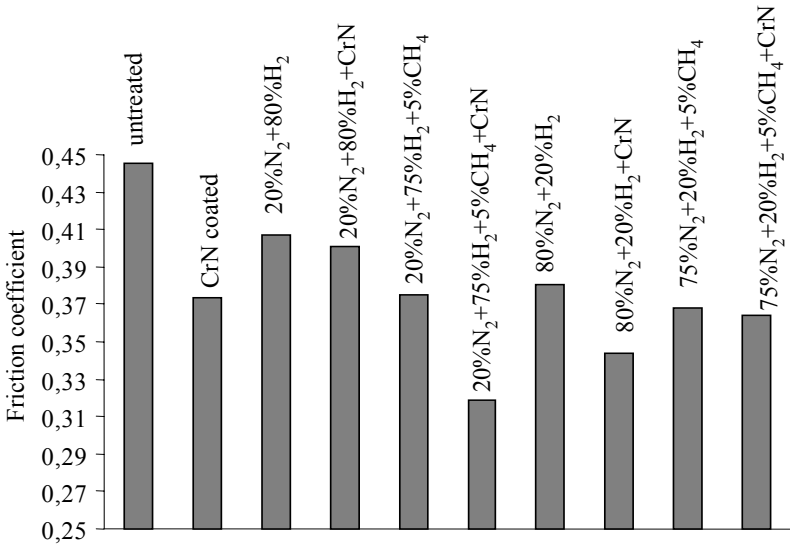

Fig. 9. Friction coefficient as a function of cutting knives type.

The 3 other nitrided knives behave the same as the coated one. Indeed, they have similar friction coefficient varying from 0,37 to 0,38 (Fig.9). As a result, a CrN layer or a nitriding with high nitrogen contents or using methane permit to increase in the same time the service life of a cutting knife. Concerning duplex treatments (Fig.8B), even for the nitrided knife in

20%N₂+80%H₂, the duplex treated knives performed best than the nitrided ones. This can be explained by a lower friction coefficient of the duplex treated knives in comparison to the nitrided or coated ones (Fig.9). The duplex treatments realised with 80%N₂+20%H₂ present the best performances but only permit to increase the tools service life by a factor of 1,8.

CONCLUSIONS

The influence of nitriding gas mixture and time on the properties of 32CrMoV13 nitrided samples was studied. It was shown that increasing the nitrogen contents from 20 to 80% or time of nitriding from 2 to 8 hours or adding 5% of methane in the nitriding gas mixture permit to increase the hardness and the thickness of the nitrided layer. It appears that nitrocarburizing is as efficient as the nitriding process and could be economically more interesting. Indeed, adding only 5% of methane in a nitriding gas mixture composed of only 20% of nitrogen allows to obtain a nitrided layer with equal mechanical properties than the one obtained with 80%N₂+20%H₂.

During peeling of beech, only the nitrided knife obtained with 20%N₂+80%H₂ performed as the untreated one, the other nitrided knives performed best as the CrN-coated one. The duplex treated knives (except the duplex treated knife obtained with 20%N₂+80%H₂) performed better than the nitrided and coated knives thanks to a lower friction coefficient and permit to machine almost twice more than the untreated one. Nevertheless, it was shown in previous study that CrN-based duplex treatments enable to increase the service life of 60SMD8 knives by a factor of 4 even if this steel material is unsuitable for nitriding (due to lack of Al, Cr...). As a conclusion, a balance between the characteristics of these two kind of steel (hardness, toughness, composition...) is necessary for a better optimisation of the application of CrN-based duplex treatments in peeling. Trials of other steels and nitriding conditions are in progress.

REFERENCES

1. Van Stappen M, Kerkhofs M, Stals LM, Quaeyhaegens C (1995) State of the art for the industrial use of ceramic PVD coatings. *Surf Coat Tech* 74-75:629-633
2. Nouveau C, Djouadi MA, Marchal R, Lambertin M (2002) Applications of hard coatings (Cr_xN_y) obtained by PVD methods in wood machining. *Méca & Indus* 3:333-342
3. Dingremont N, Pianelli A, Bergmann E, Michel H (1993) Analysis of the compatibility of plasma-nitrided steels with ceramic coatings deposited by the ion-plating technique. *Surf Coat Tech* 61:187-193
4. Dingremont N, Collignon P, Michel H, Bergmann E (1995) Optimization of duplex coatings built from nitriding and ion plating with continuous and discontinuous operation for construction and hot working steels. *Surf Coat Tech* 72:163-168
5. Bader M, Spies HJ, Höck K, Broszeit E, Schröder HJ (1998) Properties of duplex treated (gas-nitrided and PVD-TiN, -Cr₂N) low alloy steel. *Surf Coat Tech* 98:891-896
6. Navinsek B, Panjan P, Gorenjak F (2001) Improvement of hot forming manufacturing with PVD and DUPLEX coatings. *Surf Coat Tech* 137:255-264
7. Smolik J, Walkowicz J, Tacikowski J (2000) Influence of the structure of the composite : 'nitrided layer/PVD coating' on the durability of tools for hot working. *Surf Coat Tech* 125:134-140
8. Podgornik B, Vizintin J, Wänstrand O, Larsson M, Hogmark S (1999) Wear and friction behaviour of duplex treated AISI 4140 steel. *Surf Coat Tech* 120-121:502-508

9. Torbaaty S, Sprauel JM, Maeder G, Markho PH (1983) On the X-Ray diffraction method of measurement of triaxial stresses with particular reference to the angle 2θ . *Adv X-Ray Ana* 26:245-253
10. Nouveau C (2001) Etude de revêtements durs (Cr_xN_y) obtenus par méthodes PVD : réalisation et caractérisations. Applications à l'usinage du bois. Ph.D. n° 2001-21, ENSAM, Cluny, France
11. Decès-Petit C (1996) Etude des phases transitoires au cours du déroulage de bois. Ph.D. n° 9627, ENSAM, Cluny, France
12. Confente M, Michel H, Gantois M (1974) Nitruration par bombardement ionique des aciers. *Traitement Thermique* 88 :57-66
13. Barralis J, Chaize JC (1985) Caractérisation des couches nitrurées pour engrenages en 32 CDV 13 en vue d'une amélioration de leur comportement en service. *Traitement Thermique* 197 :59-65
14. Chekour L, Nouveau C, Chala A, Djouadi MA (2003) Duplex treatment of 32CrMoV13 steel by ionic nitriding and triode sputtering: applications to wood machining. *Wear* XXX:XXX-XXX *in press*